



**The EWS Family
of
Filtration and Conditioning Appliances**
The Nations #1 Whole Home
Filtration & Conditioning Appliance

Environmental Water Systems

The Best Combination of
Whole Home Filtration and Physical Conditioning
in One Appliance

Contents of the EWS Addendum:

EWS - Highlights and How to Select **2-3**

EWS - Product Category, Information, and Selection **4**

EWS-1054 - Standard Home Specification Sheets **5-6**

EWS-1354 - Series Specification Sheets **7-9**

Addendum Contents and Exhibits:

Introduction and Overview **10**

Why Filter All Your Water? **11**

What Are The Water Quality Standards? **12**

What Do These Standards Mean and How Does It Affect You? **13**

Is There A Problem With Your Water and What Should You Do? **14**

EWS - GAC Information and Filtration **15**

Hard and Soft Water Facts **16**

Softening vs. EWS Conditioning **17**

EWS Conditioning Benefits and A Final Thought **18**

Q & A **19-25**

Acknowledgements **26**

Compliances **27**

Media Replacement **28**

The "salesman cometh", a final thought **29**



Highlights of the EWS Family of Filtration and Conditioning Appliances

The Nations #1 Whole Home
Filtration & Conditioning Appliance



EWS Filtration

- Clean, healthy, quality water from every faucet in your home, every day.
- Better tasting, chlorine free water in your home.
- Healthier for oral intake (drinking) and as importantly, absorption and inhalation (from all other daily uses - washing, bathing, showering, brushing teeth, etc...)
- Clean, healthy, quality water - great for drinking, luxury bathing, steam, sauna, shower systems, cooking, and all uses.
- Healthier skin, hair and body systems.
- Natural water balance.
- High grade Granular Activated Carbon (GAC) filtration media.
- Minimal system maintenance required, 7 to 10 years prior to change out of filtration (GAC) media and ICN conditioner(s).
- Proprietary Digital Valve Technology with automatic backwash (not a brine) provides years of trouble-free operation. Our most efficient valve yet, uses the power draw of a doorbell and is easy to install and set.
- High flow rates to accommodate most any application.
- EWS units backwash and self clean. A great appliance for second homes, vacation homes or any residences. Leaving sink filtration units, in-line units and/or refrigerator filters for periods of time without usage can create problems and, unlike your EWS unit, these other units have no ability to self clean.

EWS Conditioning

- EWS conditioned water provides a nice clean feeling and not the slippery or slimy feeling (*it seems you just can't get the soap off*) as with softeners.
- Alternative to water softeners. EWS has none of the harsh effects of salts (sodium and/or potassium chloride). No salts or chemicals to add routinely.
- EWS inhibits scale formation in pipes and water heaters.
- Easier wipe off and clean up of water spotting than with untreated water.
- Use less soaps and detergents than with untreated water.
- EWS is environmentally safe with no brine discharge (as with a softener). Softeners have been actually outlawed or restricted in certain locals and need to avoid discharge into septic systems.
- EWS has no legal restrictions, warranty, or finish issues as with softeners.
- No loops or bypasses needed to avoid drinking or using softened water.



The EWS Family of Whole Home Filtration and Conditioning Appliances



EWS-1054
Standard Home
Unit up to 1" main



EWS-1354
Larger Home/Usage
Unit up to 1" main



EWS-1354-HF
Application
with 1 1/4" main



EWS-1354-11/2
Application
with 1 1/2" main

The Easy & Correct Way To Select The Proper System
on municipal water or well water of known quality*

EWS-1054

Standard unit for up to 3 baths, up to 4 people, and one water heater on 3/4"-1" service line with water of low to moderate hardness (15 grains or less).

EWS-1354

Upgraded unit for 3 or more baths, 4 or more people, and/or multiple water heaters on 3/4"-1" service line with water of moderate to high water hardness (15 grains or more).

EWS-1354-HF

Any application having 1 1/4" service line requiring greater flow rates.

EWS-1354-11/2"

Any application having 1 1/2" service line requiring greater flow rates.

Links; go to: www.ewswater.com/techandspec.html

- Service Guides for the proper set-up, install and start-up of all systems and helpful schematics for planning your next specification and installation.
- How To Determine Your Line Size.
- How To Determine The Hardness Of Your Water.
- *Guide for the Private Well Owner for the proper testing of your water to determine the proper course of action.
- Complete catalog information and tearsheets on all product available.



The Environmental Water System



The Nation's #1 Whole Home Filtration and Physical Conditioning Appliance

Item Number & Description	Filter Code
------------------------------	----------------

Standard Home or Light Commercial Application and Usage, Moderate Water Hardness
Specify for a average size home with 4 or less baths and people, with average water usage, one water heater, with 15 grains (250 ppm or mg/l) of hardness or less on 3/4" -1" service line

 <p>EWS-1054 10x54 tank with 11/2 cu.ft. of High Grade GAC Media for removal of Chlorine and VOC's. Filtration to every sink, cooking, drinking, showers, baths; for all uses. Years between media replacement and conditioning and maintenance.* ICN Conditioner physically prevents build-up in pipes/heaters, easier water spot clean-up, automatic backwashing, digital timed valve with bypass. 15 gpm on 3/4 to 1" service lines.</p>	POE-10
--	--------

Specify for Larger Homes for Greater Water Usage and/or Water Hardness
Any combination of larger sq. footage, multiple water heaters, larger service line size, larger families, greater usage and/or water hardness of 15 grains (250 ppm or mg/l) or more

 <p>EWS-1354 13 x 54 tank with 21/2 cu.ft. of High Grade GAC Media for removal of Chlorine and VOC' s. Filtration to every sink, cooking, drinking, showers, baths; for all uses. Years between media replacement and conditioning and maintenance.* Two ICN Conditioners physically prevent build-up in pipes/heaters, easier water spot clean-up, automatic backwashing, digital timed valve with bypass. 15 gpm on 3/4 to 1" service lines.</p>	POE-11
 <p>EWS-1354-HF Same as above EWS-1354 but with a 1" digital high flow (2750) valve (up to a 22 GPM) for use, if needed, on 11/4" main service. Does not include bypass</p>	POE-12
 <p>EWS-1354-11/2" Same as above EWS-1354 but with a 11/2" digital (2850) valve (up to a 50 GPM) for use on 11/2" main service. Does not include bypass</p>	POE-13

* Always know your water quality, municipally-treated or well water, (see our Guide for the Private Well Owner) water hardness and other conditions, as well as, proper applications and specifications.

Units available to suit many applications with larger valving available for larger water services.

■NO Brine Discharge ■NO Environmental Restrictions ■NO Warranty Issues with Other Products
THE BEST ALTERNATIVE TO SALT SOFTENING WITHOUT THE DISADVANTAGES.

Complete details on these and all units can be found in this Manual, Product Service Guides or on the web



Environmental Water Systems

EWS-1054

Whole Home Filtration and Conditioning Appliance

Model: EWS-1054

The EWS Series of whole home water filtration and conditioning appliances is designed to provide quality, filtered and conditioned water to the entire home, which creates a healthier water environment for you and your family.

EWS Filtration:

The granular activated carbon (GAC) high grade filtration media removes chlorine and other volatile organic compounds (VOC's), improving the taste, clarity and odor of all the water. The water can be used for all purposes; drinking and cooking, bathing and showering, steam and sauna; for you and your family, pets and plants.

EWS Conditioning:

EWS physical conditioning helps solve those problems associated with hard water without the disadvantages of softening. In use Worldwide, our catalytic process is called Increased Calcite Nucleation (ICN). Once the water has been filtered, the water travels up through the riser and the manifold containing the ICN, where the conditioner breaks apart the calcium and magnesium minerals from the bonds of the water molecules. Once in suspension, the minerals become attracted to each other and form concentric patterns which no longer adhere to surfaces, actively inhibiting scale formation.

The Result:

Easier wipe up of water spotting, better use of soaps, scale prevention within your pipes and water heater, and filtered water to your entire home. None of the salt issues of slippery feeling water, brine discharge and other problems. EWS will deliver water throughout the home at the flow rate and pressure normally found. The automatic backwash does not allow the filtration media to pack, channel or pool, this prevents any bacterial build-up and provides continued and renewed surface area for filtration. Years before media (not a cartridge) and ICN replacement based on usage and conditions. Larger units available based on water conditions, usage and/or line service size.

Benefits:

- * Alternative to Sodium or Potassium Chloride Softening
- * Easier Clean-Up of Water Spots, Better Use of Soaps
- * Actively Inhibits Scale Formation in Pipes and Water Heaters without the Corrosivity of Salt Softening
- * Improves Taste, Clarity and Odors to the Entire Home
- * Removes Chlorine and VOC's, Replaces Costly Bottled Water
- * Healthier Water for Skin, Hair and Body Systems
- * Healthier Environment for Absorption and Inhalation
- * Upgrade Your Usage of Your Spa Tubs, Shower Systems, Steam and Sauna Units, and All Your Faucets
- * Does Not Need Routine Maintenance and is Environmentally Correct

Applications:

- * Installs Easily at the Main Water Supply Line that Supplies the Home, Maintains Flow Rate and Pressure
- * No Soft Water "Loops" or Bypass Needed to Avoid Softened Water to Drinking Taps, Pools and Plants
- * Any Home with a 3/4" up to 1" Service Line
- * Drain (backwash) Water is Safe, No Brine Discharge
- * Safe for Pets, Plants, Pools, Spas and Less Harsh on Plumbing Fixtures, Accessories, Finishes and other Surfaces



EWS-1054
Standard Home Unit

Filtration options based on actual water conditions and/or consumer need, or consumer concern or preference

Whole home filtration can be combined with specific sink units for drinking (oral intake only) due to specific water problems or conditions, or consumer's needs or concerns at the point of use.

- For Removal/Safeguard of Lead and Cysts, see FUGAC250
- For Removal/Safeguard of Lead and Cysts, Bacterial, Viral, E-coli, and other Microorganisms, see UU250
- For other specific applications, see reverse osmosis systems, if applicable

Hardness minerals, naturally found Calcium and Magnesium are not contaminants nor health issues, strictly aesthetic, however;

- based on water conditions or consumer preference (you like the slippery feeling in a shower or believe the only relief is found in a softener), then add a softener (this is not a filtration product) to the hot side only, easily accessed at the inlet side to the water heater. This will compliment the EWS Appliance and limit the softener and its' usage to hot water only.

EWS, Inc. provides a complete line of filtration product from the sink to the whole home, based on your needs and concerns. Know your source water whether municipally-treated or well water and understand your needs. Do not be sold - Be Informed.



Technical Information: EWS-1054 Whole Home Filtration & Conditioning

EWS-1054

Model No.	Tank Size	Media cu. ft. / lbs	Line Size	Valve Head	Installed Unit Size	Water Flow (GPM)	Bkwash (GPM)
EWS-1054	10 in. x 54 in.	1.5 / 41	3/4 in. - 1 in.	*DTV	10 in. x 62 in.	15	4

Proper Application: EWS-1354 Series should be considered based on larger homes, larger families (5 or more), greater water usage, multiple water heaters, pools, spas, main service line (required on 1 1/4" or 1 1/2" lines for flow rate capabilities) and/or water conditions (harder water 15 grains or more), providing a greater filtration bed depth (2 1/2 cu ft) and increased conditioning capacity (2 ICN's) for increased contact and dwell time they would both provide.

MEDIA SPECIFICATIONS:

Granular Activated Carbon (GAC) - Primary Filtration Media

- Large surface area results in an exceptionally high capacity and efficiency. Activated Carbon is very hard so losses due to attrition are kept to a minimum. GAC constitutes an excellent filtration media, having a density with a balanced pore structure for more efficient operation. GAC even with it's high capacity should be replaced when the filter loses the capacity for removal of taste and odor.
- GAC is the most effective media for the removal of contaminants from water. GAC has the unique ability to adsorb chlorine from water and is the most preferred method for the complete protection from trihalomethanes (THM's) and has been proven 99% effective.
- However, no one media, resin or cartridge is capable of all things. Please refer to the GAC reference chart for capacities.
- A high grade, dedusted GAC with an iodine rating of 1200 has been selected for all CWL and EWS Series with the added Filter Ag and Filter Sand for enhancements.

GAC PHYSICAL PROPERTIES:

Color: Black, Form: Granular, Mesh Size: 12 x 40
 Density: 33lbs. / cu. ft., Water Soluble Ash: less than 0.5%
 Iodine No.: 1200 Abrasion No.: 75 min.
 Meets and complies with: American Water Works Association Standard -B604-74
 Bed Depth: 26 - 30 in., Backwash Rate: 8-10 gpm
 Backwash Bed Expansion: 30 - 40 % of bed depth

Filter Ag

Used to afford maximum removal of suspended matter throughout the filter bed and to allow the GAC media to work at maximum efficiency

- * Acts as a Pre-Sediment (20 micron) media
- * Less pressure loss, increased filter capacity
- * Light weight, lower backwash rates.

Under Bed Filter Sand

Keeps riser in place and promotes better flow and even water distribution through media bed and during backwash cycles to lift bed uniformly.

CONDITIONS FOR OPERATION:

System Service Flow Rate - up to 15 gpm
 Min/Max Water Temperature: 40° / 80 °F Min/Max Water Pressure: 40 PSI / 75 PSI Warning: Install Pressure Reducing Valve (PRV), by code in places, to prevent pressure surges and warranty issues

Cut away illustration of EWS-1054



- DTV - Digital Technology Valve: Controls automatic backwash cycles
- Warranty: Valve - 3 years
- Electrical: 24 volt for DTV operation
- Drain: 1/2" to any location
- Freeboard: Allows media space to lift during backwash
- Filtration: GAC filtration media
- Conditioning: One ICN within the riser manifold
- Tank: Tough epoxy and fiberglass outer laminate, seamless, one-piece blow molded
- Warranty: Tank - 10 years
- Stainless Steel Jacket: cover/cosmetic only, non-functional
- Lower Riser Screen and Under Bed: Water distribution

ICN Conditioner

The ICN's Field triggers a reaction (increased calcite nucleation) that changes the structure of the minerals as they relate to water molecules. Minerals become suspended and form concentric patterns into free floating disks which make the hardness minerals attach to each other and no longer adhere to hard surfaces. The ICN unit is a series of dissimilar metals which creates the field that triggers this reaction (This is not a magnet). This conditioning (not softening) process is used widely by EWS throughout the US and around the world.

Service Program 12:23 Flow P.M.

Backwash Display

Step 1 - Backwash
Step 2 - Settling
Step 3 - Rapid Rinse

*Digital Technology Valve exclusively designed by EWS to provide years of maintenance free operation.

- Easy time set
- Consumer friendly
- Easier for install/start-ups
- Shorter, yet more efficient backwash cycles

Graphic representations for illustration purposes only.

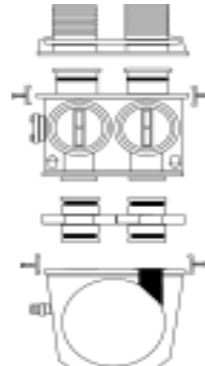

- Top/Front View of DTV using dual-port, full flow, noryl bypass with male threaded yoke.
- Shuts off water to/from the unit
 - No additional plumbing for media replacement or maintenance
 - Less costly plumbing installation, easier start-ups, non-corrosive



Environmental Water Systems

EWS-1354 Series

Whole Home Filtration and Conditioning Appliances

Models: EWS-1354, EWS-1354-HF, EWS-1354-11/2"

The EWS Series of whole home water filtration and conditioning appliances is designed to provide quality, filtered and conditioned water to the entire home, which creates a healthier water environment for you and your family.

EWS Filtration:

The granular activated carbon (GAC) high grade filtration media removes chlorine and other volatile organic compounds (VOC's), improving the taste, clarity and odor of all the water. The water can be used for all purposes; drinking and cooking, bathing and showering, steam and sauna; for you and your family, pets and plants.

EWS Conditioning:

EWS physical conditioning helps solve those problems associated with hard water without the disadvantages of softening. In use Worldwide, our catalytic process is called Increased Calcite Nucleation (ICN). Once the water has been filtered, the water travels up through the riser and the manifold containing the ICN(s), where the conditioner breaks apart the calcium and magnesium minerals from the bonds of the water molecules. Once in suspension, the minerals become attracted to each other and form concentric patterns which no longer adhere to surfaces, actively inhibiting scale formation.

The Result:

Easier wipe up of water spotting, better use of soaps, scale prevention within your pipes and water heater, and filtered water to your entire home. None of the salt issues of slippery feeling water, brine discharge and other problems.

EWS will deliver water throughout the home at the flow rate and pressure normally found. The automatic backwash does not allow the filtration media to pack, channel or pool, this prevents any bacterial build-up and provides continued and renewed surface area for filtration. Years before media (not a cartridge) and ICN replacement based on usage and conditions. Larger units available based on water conditions, usage and/or line service size.

Benefits:

- * Alternative to Sodium or Potassium Chloride Softening
- * Easier Clean-Up of Water Spots, Better Use of Soaps
- * Actively Inhibits Scale Formation in Pipes and Water Heaters without the Corrosivity of Salt Softening
- * Improves Taste, Clarity and Odors to the Entire Home
- * Removes Chlorine and VOC's, Replaces Costly Bottled Water
- * Healthier Water for Skin, Hair and Body Systems
- * Healthier Environment for Absorption and Inhalation
- * Upgrade Your Usage of Your Spa Tubs, Shower Systems, Steam and Sauna Units, and All Your Faucets
- * Does Not Need Routine Maintenance and is Environmentally Correct

Applications:

- * Installs Easily at the Main Water Supply Line that Supplies the Home, Maintains Flow Rate and Pressure
- * No Soft Water "Loops" or Bypass Needed to Avoid Softened Water to Drinking Taps, Pools and Plants
- * Any Home with a 3/4" up to 1 1/2" Service Line
- * Drain (backwash) Water is Safe, No Brine Discharge
- * Safe for Pets, Plants, Pools, Spas and Less Harsh on Plumbing Fixtures, Accessories, Finishes and other Surfaces



EWS-1354
Upgraded Home Unit for Harder Water, Greater Usage, or Larger Homes

Filtration options based on actual water conditions and/or consumer need, or consumer concern or preference

Whole home filtration can be combined with specific sink units for drinking (oral intake only) due to specific water problems or conditions, or consumer's needs or concerns at the point of use.

- For Removal/Safeguard of Lead and Cysts, see FUGAC250
- For Removal/Safeguard of Lead and Cysts, Bacterial, Viral, E-coli, and other Microorganisms, see UU250
- For other specific applications, see reverse osmosis systems, if applicable

Hardness minerals, naturally found Calcium and Magnesium are not contaminants nor health issues, strictly aesthetic, however;

- based on water conditions or consumer preference (you like the slippery feeling in a shower or believe the only relief is found in a softener), then add a softener (this is not a filtration product) to the hot side only, easily accessed at the inlet side to the water heater. This will compliment the EWS Appliance and limit the softener and its' usage to hot water only.

EWS, Inc. provides a complete line of filtration product from the sink to the whole home, based on your needs and concerns. Know your source water whether municipally-treated or well water and understand your needs. Do not be sold - Be Informed.



EWS-1354 Series

Technical Information: EWS-1354 Series: Whole Home Filtration & Conditioning

Model No.	Tank Size	Media Content cu. ft. / lbs	Line Size	Valve Head	Installed Unit Size	Water Flow (GPM)	Backwash (GPM)
EWS-1354	13 in. x 54 in.	2.5/68	3/4 - 1"	*DTV	13 in. x 63 in.	15	7
EWS-1354-HF	13 in. x 54 in.	2.5/68	1 - 1 1/4"	DTV-HF	13 in. x 63 in.	22	7
EWS-1354-11/2	13 in. x 54 in.	2.5/68	1 1/2"	DTV-11/2"	13 in. x 63 in.	50	10

MEDIA SPECIFICATIONS:

Granular Activated Carbon (GAC) - Primary Filtration Media

- Large surface area results in an exceptionally high capacity and efficiency. Activated Carbon is very hard so losses due to attrition are kept to a minimum. GAC constitutes an excellent filtration media, having a density with a balanced pore structure for more efficient operation. GAC even with it's high capacity should be replaced when the filter loses the capacity for removal of taste and odor.
- GAC is the most effective media for the removal of contaminants from water. GAC has the unique ability to adsorb chlorine from water and is the most preferred method for the complete protection from trihalomethanes (THM's) and has been proven 99% effective.
- However, no one media, resin or cartridge is capable of all things. Please refer to the GAC reference chart for capacities.
- A high grade, dedusted GAC with an iodine rating of 1200 has been selected for all CWL and EWS Series with the added Filter Ag and Filter Sand for enhancements.

GAC PHYSICAL PROPERTIES:

Color: Black, Form: Granular, Mesh Size: 12 x 40
 Density: 33lbs. / cu. ft., Water Soluble Ash: less than 0.5%
 Iodine No.: 1200 Abrasion No.: 75 min.
 Meets and complies with: American Water Works Association Standard -B604-74
 Bed Depth: 26 - 30 in., Backwash Rate: 8-10 gpm
 Backwash Bed Expansion: 30 - 40 % of bed depth

Filter Ag

- Used to afford maximum removal of suspended matter throughout the filter bed and to allow the GAC media to work at maximum efficiency
- * Acts as a Pre-Sediment (20 micron) media
 - * Less pressure loss, increased filter capacity
 - * Light weight, lower backwash rates.

Under Bed Filter Sand

Keeps riser in place and promotes better flow and even water distribution through media bed and during backwash cycles to lift bed uniformly.

CONDITIONS FOR OPERATION:

System Service Flow Rates - up to 15, 22, or 50 gpm
 Min/Max Water Temperature: 40° / 80 °F Min/Max Water Pressure: 40 PSI / 75 PSI
 Warning: Install Pressure Reducing Valve (PRV), by code in places, to prevent pressure surges and warranty issues

Cut away illustration of EWS-1354 for 1" service line



- DTV - Digital Technology Valve: Controls automatic backwash cycles
Warranty: Valve - 3 years
- Electrical: 24 volt for DTV operation
- Drain: 1/2" to any location
- Freeboard: Allows media space to lift during backwash
- Filtration: GAC filtration media 21/2 cu. ft
- Conditioning: Two ICN's within the riser manifold for greater conditioning capacities
- Tank: Tough epoxy and fiberglass outer laminate, seamless, one-piece blow molded
Warranty: Tank - 10 years
- Stainless Steel Jacket: cover/cosmetic only, non-functional
- Lower Riser Screen and Under Bed: Water distribution

ICN Conditioner

The ICN's Field triggers a reaction (increased calcite nucleation) that changes the structure of the minerals as they relate to water molecules. Minerals become suspended and form concentric patterns into free floating disks which make the hardness minerals attach to each other and no longer adhere to hard surfaces. The ICN unit is a series of dissimilar metals which creates the field that triggers this reaction (This is not a magnet). This conditioning (not softening) process is used widely by EWS throughout the US and around the world.

Service Program 12:23 Flow P.M.

↻

^

v

Backwash Display

Step 1 - Backwash

Step 2 - Settling

Step 3 - Rapid Rinse

- *Digital Technology Valve exclusively designed by EWS to provide years of maintenance free operation.
 - Easy time set
 - Consumer friendly
 - Easier for install/start-ups
 - Shorter, yet more efficient backwash cycles
- Graphic representations for illustration purposes only.

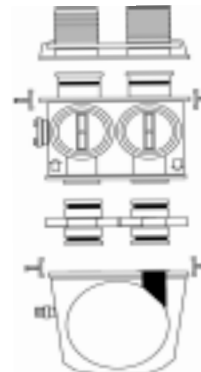

Top/Front View of DTV using dual-port, full flow, noryl bypass with male threaded yoke.

This is the supplied and required bypass on all EWS-1054 and EWS-1354 units

See other valves and installed bypass options and schematics on following page



EWS Series - Whole Home Filtration and Conditioning Appliances Summary Technical Information and Schematics

- Three Valve Options and Set-ups
- Only One Digital Control

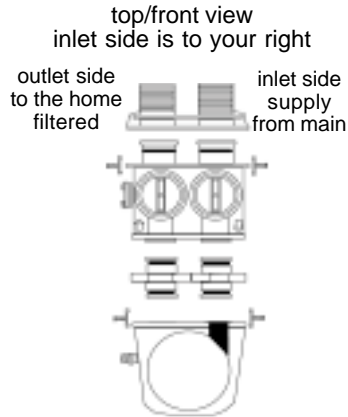

EWS-1054 or EWS-1354
 Service Line Size: 3/4" - 1"
 Drain Line Size: 1/2"
 Installed Dimensions:
 Height: 63"
 Dry Weight: 125 lbs.
 Width: 13"
 Clearance: allow 18" for plumbing
 Bypass included must be installed with 1" DTV valves

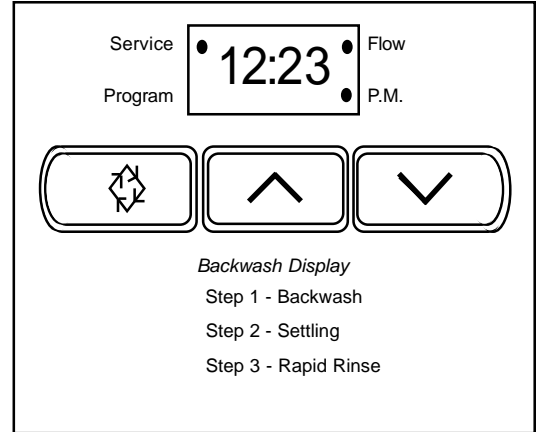

Digital Valve Control Face for all EWS Appliances with 1", HF or 11/2" valves

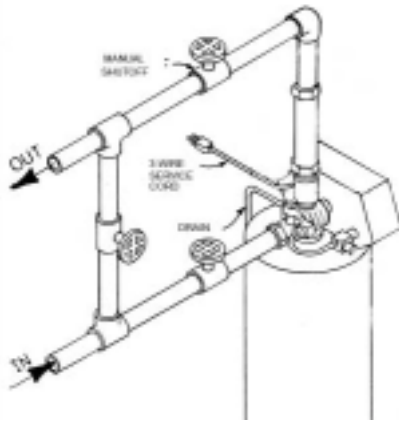

EWS-1354-HF
Valve (DTV-HF, 2750) Bypass is Plumber Installed as illustrated

EWS-1354-HF
 Service Line Size: 1-11/4"
 Drain Line Size: 1/2"
 Installed Dimensions:
 Height: 63" (top of valve)
 Dry Weight: 155 lbs.
 Width: 13"
 Clearance: allow 2' for plumbing
 Bypass required with 3 valves and unions for quick disconnect for media replacement, maintenance and warranty

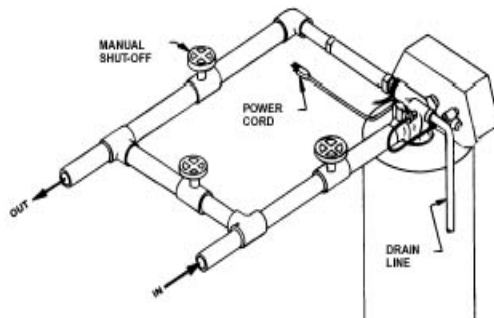

EWS-1354-11/2"
Valve (DTV-11/2", 2850) Bypass is Plumber Installed as illustrated

EWS-1354-11/2"
 Service Line Size: 1 1/2"
 Drain Line Size: 3/4"
 Installed Dimensions:
 Height: 63" (top of valve)
 Dry Weight: 165 lbs.
 Width: 13"
 Clearance: allow 2' for plumbing
 Bypass required with 3 valves and unions for quick disconnect for media replacement, maintenance and warranty

***Digital Technology Valve exclusively designed by EWS to provide years of maintenance free operation.**

- Easy time set button up or down to set time
- Consumer friendly easy read out and simple to manually (if needed) backwash with one press of the recycle button
- Easier for install/start-ups
Follow the easy install instructions in our service guide
- Shorter, yet more efficient backwash cycles
- No mechanical timer motors to wear out
- Redesigned drain outlet prevents cracking drain port and restrictor from overtightening
- Time of backwash can be adjusted to a different time of day



Introduction and Overview

The Environmental Water System Whole-Home Filtration and Conditioning Appliance

The Environmental Water System combines in one appliance, a high grade of Granular Activated Carbon to filter water to the whole home and our ICN Conditioner(s) for physical conditioning, as an alternative to salt softening.

Environmental Water Systems (EWS) filters and conditions all your water to your home for a healthier lifestyle. EWS Water Conditioning causes a physical change in how naturally found calcium and magnesium minerals react in your water and on your surfaces. EWS keeps these essential minerals in your water for a pure, fresh taste while helping to solve the problems associated with hard water.

In each appliance, water is filtered through the media bed of Granular Activated Carbon (GAC), and then conditioned as it passes through the ICN Conditioner(s) on its way to your home. The ICN Conditioner breaks apart the calcium and magnesium minerals, that easily adhere to surfaces (including your skin), from the bonds of the water molecules. Once in suspension, the minerals become attracted to each other and form concentric patterns which no longer adhere to surfaces, actively inhibiting scale formation. EWS Conditioning will inhibit scale formation in your pipes and water heaters while making better use of soaps and cleaners and an easier wipe up of water spots in your daily routines.

In use Worldwide, our catalytic process is called, Increased Calcite Nucleation (ICN). Baking soda and other surfactants have been used in soaps and detergents for years to create the same ICN reaction, allowing soaps to work regardless of water conditions.

EWS Water Conditioning should not be confused with water softening. Softening is the exchange of naturally found minerals for either sodium or potassium chloride. Softening is not a filtration product. Softening can be very aggressive and has many trade-offs, disadvantages, slippery feeling, routine maintenance, and even legal restrictions. EWS employs an environmental approach to water hardness issues, while allowing you to enjoy filtered water throughout your home.

The Environmental Water System is like having a bottled drinking water factory in your home. Most filtration systems, some of which we also manufacture, are devices that hook directly to the cold water supply under your sink. This provides you with varying degrees of filtered water limited to that tap only. EWS Filtration is designed to provide you filtered water to the entire home. EWS provides filtered water for your consumption and usage at all your sinks, and filtered water for your consumption, absorption and inhalation during bathing, showering, steam or sauna. EWS Filtration provides a healthier, cleaner, quality water environment for you, your family, and your home. In addition, EWS Conditioning helps solve those problems associated with hard water without the disadvantages of salt-softening and brine discharge.

EWS saves you money. Now you can filter and condition water to your entire home without the continual maintenance. Environmental Water Systems uses no salts or other additives and EWS filtration is provided for years before GAC media needs replacement. Enjoy the benefits of conditioned and filtered, quality water for fractions of a penny per gallon.

Your professional plumber or builder can install an Environmental Water System to the main water supply to your home in a couple of hours. The EWS Appliance incorporates the EWS Digital Technology Valve and is extremely user friendly. The system automatically backwashes itself, once installed, it's set and leave it alone. The EWS system also takes up less room than a soft water system, does not take up vital kitchen cabinet space, there are no bags of salt to lift, or filters to buy.

Quality, clean, healthier water from every tap, for all your uses, every day.

This is an overview. The following pages provide a perspective on filtration and then conditioning. It is our goal to provide factual information so you may make an informed decision. We will answer questions and provide information on water quality, GAC and filtration. Secondly, we will answer questions and provide information on hard and soft water, softeners and conditioners, and the ICN. Additionally, installation instructions and customer service information may provide additional insights into the Environmental Water System.

Thank you for your consideration. *Be informed - not sold.* An informed consumer is our best customer.

**If given the opportunity, why would you filter all the water to your home?****You know water is very important to you!**

The body is composed of 70-80% water. Water is one of the four main nutrients of the body. A healthy human being can go without food for two weeks but only three days without water. Many vital functions and all chemical reactions in the body take place in the medium of water. Water aids in all bodily processes - assimilation of nutrients, digestion, circulation and elimination. Water lubricates the joints of the body and helps regulate its' temperature. Drinking sufficient quantities of water helps flush out impurities, discourages bloating and the retention of water, and helps restore moisture to the skin and hair, while discouraging wrinkles and dryness.

■ You know there are several ways to intake water!

- Drinking: Water may be ingested, ie: water, coffee, tea, ice and mixes.
- Absorption: Taking a shower exposes you to the equivalent of consuming an additional 1/2 gallon of water each day. After soaking in a bath tub or spa for ten minutes, you may be up to 4 lbs. heavier upon your exit.
- Inhalation and absorption: The greatest intake may be your shower, where gases are vaporized. Inhalation exposure was found to be comparable to direct ingestion. Steam and sauna are included.

■ Without getting paranoid, you know you have concerns with water, as well as, many other things!

Chlorine is used almost universally in the treatment of public drinking water because of its toxic effect on harmful bacteria and other waterborne, disease-causing organisms. But there is a growing body of scientific evidence that shows chlorine in drinking water may actually pose greater long-term dangers than those for which it was used to eliminate. These effects of chlorine may result from either ingestion or absorption through skin. Scientific studies have linked chlorine and chlorination by-products to cancer of the bladder, liver, stomach, rectum and colon, as well as, heart disease, anemia, high blood pressure, and allergic reactions and skin sensitivities. We know chlorine has issues with protein in our body and that of the skin and hair, just remember the last time you were in a pool.

Problems also arise from other chemical compounds. These compounds include, but are not limited to, chemicals associated with various pesticides, herbicides, fuels, dyes, solvents, and industrial and agricultural by-products. Misuse of these materials and/or improper storage and disposal has allowed drinking water supplies to become suspect. Trace elements of these chemicals may be within acceptable limits, however their long-term effects are unknown. Since chlorine, other disinfectants, their by-products, and other chemical compounds are present in our municipal supplies, one might want to remove these substances at the point of entry.

■ Did you know, there is a product for you!

The EWS Series of Whole Home Filtration and Conditioning Appliances by EWS, Inc. can be installed at your main water supply line and filter all the water entering your home of the chlorine and other volatile organic compounds while conditioning the natural occurring hardness minerals (calcium & magnesium) without the disadvantages of harsh salt softening.

Filtration to the whole home is a wonderful experience and of all the great things you put into your new, remodeled or existing home, this is the one device that will be used by every member of the family, everyday. Showering, bathing, steam, sauna or just brushing your teeth is cleaner, tastier and healthier. The harsh elements you eliminate for yourself also protects your fixtures and finishes over the long term from these same chemical compounds.

■ They laughed back then!

Years ago, central heating and air conditioning was an option, that has become a standard feature in all homes. Now, heating and air conditioning units have advanced (de-) humidification and air filtration devices to improve the air quality in your home.

Central heat & a/c, Central vacuuming, Central alarm, Now, Central water. Luxury spa tubs and shower systems are commonplace, yet how luxurious can they be, using unfiltered, chlorinated, municipally-treated tap water?

EWS Filtration and Conditioning to the Whole Home is becoming a recognized upgrade; to your home, your lifestyle and your health.

■ Our commitment to you!

EWS, Inc. manufactures and provides a complete line of water filtration, softening and conditioning product from sink to whole home. We provide the information that enables the consumer to choose the right product for their water conditions and their concerns. Sold only through building wholesale supply, kitchen & bath showrooms, and appliance dealers, EWS, Inc. has been pioneering its' series of whole home filtration appliances for over 20 years to those consumers willing to be informed and not sold.

If there are specific water issues or consumer concerns, whole home filtration can be combined with specific sink (point of use) applications for oral intake (drinking) only.



What Are The Water Quality Standards?

The next page will tell you what this means and how it affects you.

Standards for Municipally Treated Water (California Dept. of Health Services)

HOW TO READ THE CHART

Read across the chart starting with name of the test, the unit of measurement, and the maximum contaminant level allowed. These are grouped by type; organic chemicals, inorganic chemicals, radionuclides, aesthetic standards and additional parameters.

PRIMARY STANDARDS - Mandatory Health-Related Standards			PRIMARY STANDARDS - Mandatory Health-Related Standards		
Parameter	Units	MCL	Parameter	Units	MCL
Microbiological			Inorganic Chemicals		
Coliform Bacteria	# acute violations	0 (none)	Aluminum	mg/l	1.0
Organic Chemicals			Arsenic	mg/l	0.005
Total trihalomethanes	mg/l	0.10	Barium	mg/l	1.0
Endrin	mg/l	0.0002	Cadmium	mg/l	0.01
Lindane	mg/l	0.004	Chromium	mg/l	0.05
Methoxychlor	mg/l	0.01	Fluoride	mg/l	1.4
Toxaphene	mg/l	0.005	Lead	mg/l	0.05
2, 4-D	mg/l	0.1	Mercury	mg/l	0.002
2, 4, 5-TP Silvex	mg/l	0.01	Nitrate	mg/l	10.0
Atrazine	mg/l	0.003	Nitrite	mg/l	1.0
Bentazon	mg/l	0.018	Selenium	mg/l	0.01
Benzene	mg/l	0.001	Silver	mg/l	0.05
Carbon Tetrachloride	mg/l	0.0005	Radioactivity		
1, 2-Dibromo-3-Chloropropane	mg/l	0.0002	Gross Alpha Activity	pCi/l	15
1, 2-, 4-Dichlorobenzene	mg/l	0.005	Gross Beta Activity	pCi/l	50
1, 1-, 2-Dichloroethane	mg/l	0.005	Tritium	pCi/l	20,000
1, 1-Dichloroethylene	mg/l	0.006	Strontium-90	pCi/l	8
1, 2-, 3-Dichloropropane	mg/l	0.005	Radium 226 and 228 combined	pCi/l	5
Dichloromethane	mg/l	0.005	Uranium	pCi/l	15
Ethylbenzene	mg/l	0.680	SECONDARY STANDARDS - NON-HEALTH RELATED		
Ethylene Dibromide	mg/l	0.00002	Aesthetic Standards set by CDHS		
Molinate	mg/l	0.02	Parameter	Units	MCL
Monochlorobenzene	mg/l	0.03	Color	units	15
Simazine	mg/l	0.01	Odor-Threshold	units	3
Sytrene	mg/l	0.1	Chloride	mg/l	500
1, 1, 2, 2-Tetrachloroethane	mg/l	0.001	Copper	mg/l	1.0
Tetrachloroethane	mg/l	0.005	Foaming Agents (MBAS)	mg/l	0.5
Thiobencarb	mg/l	0.07	Iron	mg/l	0.3
Toluene	mg/l	0.15	Manganese	mg/l	0.05
1, 2, 4-Trichlorobenzene	mg/l	0.07	Sulfate	mg/l	500
1, 1, 1-Trichloroethane	mg/l	0.200	Zinc	mg/l	5.0
1, 1, 2-Trichloroethane	mg/l	0.032	Total Dissolved Solids	mg/l	1,000
Trichloroethylene	mg/l	0.005	Additional Constituents Analyzed		
Vinyl Chloride	mg/l	0.0005	MCL - No Standards Set (nss)		
Xylenes	mg/l	1.750	Parameter	Units	MCL
Cis-1, 2-Dichloroethylene	mg/l	0.006	pH	units	nss
Trans-1, 2-Dichloroethylene	mg/l	0.01	Hardness (CaCO3)	mg/l	nss
Trichlorofluoromethane (Freon 11)	mg/l	0.15	Sodium (NaCl)	mg/l	nss
Carbofuran	mg/l	0.018	Calcium	mg/l	nss
Glyphosphate	mg/l	0.7	Potassium (K)	mg/l	nss
Chlordane	mg/l	0.0001	Magnesium (Mg)	mg/l	nss
Heptachlor	mg/l	0.00001	This is an exhibit of published information available to consumers. Most districts have summary pamphlets with standard language (see next page). Contact your water district for your specific results.		
Heptachlor Epoxide	mg/l	0.00001			
Di (2-ethylhexyl) phthalate	mg/l	0.004			
Alachlor	mg/l	0.002			
Dalapon	mg/l	0.2			
Dinoseb	mg/l	0.007			
Diquat	mg/l	0.02			
Endothall	mg/l	0.1			
Oxamyl	mg/l	0.2			
Pentachlorophenol	mg/l	0.001			
Polychlorinated Biphenyls	mg/l	0.0005			

MCL = maximum contamination level



What do these water standards mean and how do they affect you?

Most municipal water districts are attempting to do the best job of providing safe drinking water to their communities. There are many issues concerning our health and that of our families. Air, water and food supplies are all suspect. It is our goal to make some sense of water issues and provide information, in order for consumers to make educated decisions.

The following are excerpts from the standard language provided to consumers requesting information about their water supply in their community. This is a great place to start because it sets the table for a good general understanding of water issues and how we may compliment the water through filtration or reduce any particular issues of actual concern.

Contaminants that may be present in source water include:

Microbial contaminants, such as viruses and bacteria, that may come from sewage treatment plants, septic systems, agricultural livestock operations, and wildlife.

Inorganic contaminants, such as salts and metals, that can be naturally-occurring or result from urban storm water runoff, industrial or domestic wastewater discharges, oil and gas production, mining, or farming.

Pesticides and herbicides, that may come from a variety of sources such as agriculture, urban storm water runoff, and residential uses.

Organic chemical contaminants, including synthetic and volatile organic chemicals, that are by-products of industrial processes and petroleum production, and can also come from gas stations, urban storm water runoff, agricultural application, and septic systems.

Radioactive contaminants, that can be naturally-occurring or be the result of oil and gas production and mining activities.

All municipally-treated drinking water is subjected to extensive testing, not only for regulated contaminants, but also for non-regulated as well. For example, the Cities of Vacaville, CA. and Las Vegas, NV. performed more than 70,000 tests on water samples throughout the year, which is typical of most water districts. Water districts also conduct source Water Assessments and Vulnerability Studies. This study evaluates the quality of the water used as drinking water supplies for local communities. The assessment survey examines activities associated with the specific waterway and surrounding areas to determine potential contamination. Any potential contributors are then compiled into a Vulnerability Summary.

Now, what is a local door-to-door water salesman going to test for?

Usually, the naturally-found calcium and magnesium minerals, which are not contaminants (see water standards) in order to "pitch" a water softener. A reverse osmosis system will be added to the "pitch", in order to remove the salt, the softener put in, so you have something to drink! Interesting to note, those assessment studies have been making recommendations in over 30 states to restrict softeners due to the brine discharge. The use of reverse osmosis systems have been questioned. They are greatly misapplied and can waste up to 20 gallons of rejection water for every gallon of water produced.

Water in the News

Security is an issue that concerns us all. Federal, State and Local Agencies, partnered with the various water agencies, are taking precautionary measures to provide safe, clean drinking water to their citizens.

However, a toxic chemical introduced into a municipal system would dissipate over millions of gallons of water rendering it harmless.

The Flavor of the Day, Chromium, Arsenic, MTBE, Trihalomethanes (THMs) are samples of many items that may create issues with our water supplies.

Ironically, chlorine used to disinfect our water, is one of the most toxic chemicals on any list.

You can smell and taste it and easily test for it. It is the reason most people buy bottled water or filter at the sink. EWS can filter the chlorine and the associated volatile organic compounds (VOC's) once the chlorine has disinfected the water.

Special Information

Some people may be more vulnerable to contaminants in drinking water than the general population. Immuno-compromised people such as those with cancer undergoing chemotherapy, people who have undergone organ transplants, people with HIV/AIDS or other immune system disorders, some elderly, and infants can be particularly at risk from infections. These people should seek advice about drinking water from their health care providers on appropriate means to lessen the risk of infection by Cryptosporidium and other microbial contaminants.

Most people simply want better tasting water, others have greater concerns.

EWS Filtration to the whole home takes care of the chlorine and VOC's and is a great compliment to most municipal water for most people. EWS Filtration to the whole home is also a healthier water environment for skin, hair and body systems due to absorption and inhalation. However, specific sink applications are available, and can be combined with whole home filtration for specific problems or concerns at the sink for drinking, cooking and other uses.



Is there a problem with your water and what should you do?

Common water quality concerns explained:

Water comes out of tap white and "foamy", this goes away when the water sits for a time. Air in the water will give the appearance of "foam" or white particles. This is not a health concern and does not affect the quality of the drinking water.

Water smells bad, often at only one sink. Sink p-traps become clogged over time with food and other waste residues. As waste residues decay offensive odors can result. This can lead to a backup of odor, especially when the hot water is run. Flushing drains regularly will reduce or eliminate p-trap odor backup.

Black particles are in the water. This is often due to the breakdown of the black rubber inside some types of flexible braided hoses connected to the hot water system. Check and replace with hoses that do not contain rubber.

Water is yellow or brown only for a short period of time. Occasionally, fire hydrants are opened or water lines are repaired, resulting in the dislodging of particles into the water. When this occurs, open large taps and flush water until the water clears.

Strong chlorine smell, water tastes like chlorine. Water supplies can consist of ground water from wells, aquifers, lakes, reservoirs, aqueducts, etc.. All water sources have different properties which affect the way they respond to chlorination. Chlorination is necessary to prevent health risks, but can cause changes in taste and odor. To improve the taste of the water, try leaving the water standing in a pitcher or add a slice of lemon. Water purification filters that contain activated carbon also may improve the taste of the water.

Chlorine and other disinfectants used by water districts are "double-edged swords". On one hand, these chemicals are effective, on the other hand, there is mounting evidence of the problems associated with these compounds.

Water causes spots on surfaces.

Our water may be considered hard to some extent. This can cause some water spots and deposits on fixtures and other surfaces. Some residents remove the hardness, with is naturally found calcium and magnesium minerals, with a "water softener," which replaces these hardness minerals with sodium. If a water softener is used, it should only be connected to the inlet of the hot water heater, so not to add sodium to the cold water for drinking.

This and every water district in California makes the same statement, unless that area actually has an outright ban on softeners. Note the statement tells a truth a salesman selling softeners is not going to tell you! Softeners add salt to the water and you should not drink softened water. Softeners are not filtration devices and offer no water quality improvement for you, your family or your home. If the salesman offers you potassium instead of salt, bear in mind, he's playing with semantics. The potassium he's offering, as a salt substitute, is potassium chloride and is just another salt with all the same problems. Our discussion on softening vs. EWS conditioning will begin, once you have a good perspective on filtration.

Know something about your water, call your municipal water district. If you're on your own well or on a small unregulated system have the water independently tested for complete results on the health of your water. (please see our section on well water and potential problem-solving)

The next page gives you a perspective on how the EWS - Environmental Water System - Whole Home Filtration and Conditioning Appliance can compliment your water by providing great, clean, quality, chlorine-free water to the entire home, to all your fixtures, showers, tubs, steam, sauna, refrigerator, ice-makers, for all your uses. See the GAC information and filtration chart for a summary of removal capabilities and the GAC incorporated in all EWS Appliances.

In order to ensure that tap water is safe to drink, the U.S Environmental Protection Agency (USEPA) and the State Department of Health Services or other state agency, prescribe regulations that limit the amount of certain contaminants in water provided by public water systems.

Water districts make a commitment to ensure that your water meets the highest water quality standards and is a reliable source. Drinking water may reasonably be expected to contain at least small amounts of some contaminants. The presence of contaminants does not necessarily indicate that water poses a health risk.



EWS - GAC Information and Filtration

Granular Activated Carbon (GAC) constitutes an excellent filtration media, having a high density with a balanced pore structure for more efficient adsorption. EWS, Inc. uses a unique Granular Activated Carbon system to filter all the water to the home. GAC has long been recognized as an effective and reliable material for removing impurities. The primary raw material used for activated carbon is any organic material with a high carbon content. Once the carbon based materials are activated by thermal decomposition the resultant product has an incredibly large surface area per unit volume and a network of submicroscopic pores where the adsorption takes place.

Whole Home Filtration by EWS, Inc.

EWS, Inc. uses a proprietary raw, natural organic material for activation, which creates an incredible surface area of 800 square meters per gram of material, or over 3,000 football fields of surface area per 11/2 cubic feet (41-42 lbs.), which we use in our standard CWL or EWS units (21/2 cu.ft./65 lbs. in all 1354 Series). This high grade, dedusted, Granular Activated Carbon has a minimum iodine rating of 1200 and has been selected for use in all CWL Series (whole home filtration appliances) and the Environmental Water Systems Series of whole home water filtration and conditioning appliances for optimum use and filtration.

Granular Activated Carbon (GAC) Reference List

Below is a simple reference chart to give some perspective as to GAC's capabilities with various substances. Some items are heavy metals and inorganics, while others are VOC's (volatile organic compounds), some of which are man-made pollutants. Still other items, such as hardness, are not even considered contaminants. In general, GAC is very economical and a great compliment to municipally-treated water without the disadvantages of more aggressive filtration. See our information on well water, the process of testing and proper applications. GAC is used in all filtration due to its removal capacities. Know your water to select the correct product for you, your family and your home.

Upgrade options to solve specific water issues or consumer concerns for drinking (oral intake) can be accomplished with the proper sink (point of use) system as a compliment to whole home filtration.

Acetaldehyde	4	Emulsions	2	Lead	3	Precipitated Sulfur	2
Acetic Acid	3	Ethyl Acetate	5	Lime	0	Propioic Acid	4
Acetone	4	Ethyl Acrylate	5	Mercaptans	4	Propionaldehyde	3
Alcohols	4	Ethyl Alcohol	4	Metal Salts	1	Propyl Acetate	4
Alkalinity	1	Ethyl Amine	4	Methyl Acetate	4	Propyl Alcohol	4
Amines	3	Ethyl Chloride	4	Methyl Alcohol	4	Propyl Chloride	4
Ammonia	1	Ethyl Ether	4	Methyl Bromide	5	Radon	4
Amyl Acetate	5	Fertilizers	1	Methyl Chloride	4	Rubber Hose Taste	5
Amyl Alcohol	5	Fluorides	2	Methyl Ethyl Ketone	5	Seawater	1
Antifreeze	4	Formaldehyde	2	Naphtha	5	Sediment	2
Arsenic	1	Gasoline	5	Nitrates	0	Soap	3
Benzene	5	Glycols	5	Nitric Acid	3	Sodium Hypochlorite	5
Bleach	5	Hardness	0	Nitrobenzene	5	Soluble Iron	2
Boron	1	Heavy Metals	3	Nitrotoluene	5	Solvents	4
Butly Alcohol	5	Herbicides	5	Odors (General)	5	Sulfuric Acid	1
Butly Acetate	5	Hydrogen Bromide	2	Oil - Dissolved	5	Sulphonated Oils	4
Calcium Hypochlorite	5	Hydrogen Chloride	1	Oil - Suspended	2	Suspended Matter	2
Carbon Dioxide	0	Hydrogen Fluoride	1	Organic Acids	4	Tannins	4
Chloral	5	Hydrogen Iodide	2	Organic Esters	5	Tar Emulsion	4
Chloramine	4	Hydrogen Peroxide	5	Organic Salts	4	Tartaric Acid	4
Chloroform	5	Hydrogen Selenide	3	Oxalic Acid	5	Taste (DI Water)	4
Chlorine	5	Hydrogen Sulfide	3	Oxygen	5	Taste (From Organics)	4
Clorobenzene	5	Hydrochlorous Acid	5	Ozone	4	THM's	5
Chlorophenol	5	Inorganic Acids	1	PCB's	5	Toluene	5
Chlorophyll	4	Inorganic Chemicals	1	Pesticides	5	Toluidine	5
Citric Acid	4	Insecticides	5	Phenol	5	Trichlorethylene	5
Cresol	5	Iodine	5	Phosphates	0	Turpentine	5
Defoliants	5	Isopropyl Acetate	5	Plastic Taste	5	Urine	2
Detergents	3	Isopropyl Alcohol	5	Plating Wastes	3	Vinegar	3
Diesel Fuel	5	Ketones	5	Potassium Permanganate	4	Xanthophyll	4
Dyes	5			Precipitated Iron	2	Xylene	5

KEY TO THE ABOVE LIST:

5- EXCELLENT - A proven application 4- VERY GOOD - A proven application 3- GOOD - very acceptable result
2- FAIR - limited application 1- POOR - not a recommended application 0- Not an application for GAC



Hard and Soft Water Facts

A HARD WATER PERSPECTIVE AND ITS TREATMENT

Hard water can be a multi-million dollar problem for individuals and business. Scale formation can increase the cost of equipment maintenance, shorten equipment life, decreased water heater efficiency requires greater usage of soaps and cleaners and can simply waste time and energy.

The hardness of water is determined by the amount of calcium and magnesium in the water. Calcium carbonate molecules solidify instantly when they come in contact with any hard surface and then grow upon themselves in every direction. Because of their tree-like shape they are called dendritic crystals. They constitute the beginning of the formation of lime scale.

It is important to note that the hardness minerals are a component of the total dissolved solids (TDS) in your water. These minerals and the TDS are generally an aesthetic consideration (as evidenced in your water standards) and not a consumption problem. By definition, hard water has these minerals and naturally soft water is low or devoid of this mineral content. Hard water can build up, yet can be maintained or properly treated. However, it is important to note, soft water is aggressive and corrosive. If the water is soft, the water will naturally seek to balance itself by leaching any minerals found in its' path. This creates problems for a diverse amount of water features such as; copper pipe, finishes, pools and spas, to name a few. Ironically, hard water is considered healthier (note: bottled water adds back minerals and spring water from natural sources all have a mineral content, from low to very high for taste). Hard water has greater properties of assimilation, then that of aggressive soft water. Of all the water on our planet, most is sea water and is undrinkable. Of the limited supply of fresh water available, most is hard to some extent or another.

SOFTENING - THE HARD FACTS

Softening has been around since the 1920's. In the process of softening, calcium and magnesium ions are removed from the water and replaced by sodium ions in a process called ionic exchange. The use of sodium or potassium chloride is used in this process. In this process the minerals have been exchanged for a salt, and in fact the TDS remains the same or in some instances is greater. The results are prevention of lime scale in your water heater or pipes, easier wipe up of water spots and the better use of soaps. Dishwasher results improve, but only if you use your appliance properly.

However, the disadvantages are an aggressive and corrosive water that needs to be bypassed from drinking and from equipment such as the pool or spa, otherwise you may void their warranty. The exchange of the minerals for a salt creates a two-fold problem; one, the water now lacks the minerals making it soft and aggressive, and two, the water has a sodium or potassium chloride content making the water more corrosive. Remember, your TDS has remained the same. Something has replaced your calcium and magnesium minerals!

"Softened" water has a slippery feeling in the shower due to the new make up of the water (it's the salt, not the natural oils from your skin that the salesman told you!). If a softener is on all your water, you may be asked to put a reverse osmosis at your kitchen sink, so you can remove the salt from the water the softener put in, and have a tap to drink from! Some homes now have soft water loops, because the water from a softener has its consumption and warranty issues. The loop bypasses the softener to provide unsoftened water to your kitchen sink, ice maker and hose bibs. If the water from a softener should be bypassed or filtered, and is not necessarily good to drink, why would you bathe or shower in it? TDS (now with a higher salt content) in water will still require you to maintain swamp and evaporative coolers, humidifiers, steam irons, shower heads, aerators and any items where the water is processed through small pores and restricted flow rates. Due to the corrosive or aggressive nature of softened water you may find a written or implied warranty issue with manufacturers of these and other products.

Please note that softeners do not filter, they soften. The marketing of problems associated with hard water relates more to selling softeners than actual fact. How do people achieve results without treatment? You still have to use your clothes washer and dishwasher properly to get good results. Water heaters should be flushed for longer life. If you soften the water be aware of the corrosion at the bottom of your heater over time. Surfaces can and should be sealed and all detergents are now formulated for low suds (add salt and soaps suds up) - suds do not clean!

The nature of softening product is a trade off of problems, not necessarily a solution. Last issue is the environmental one; water softeners are already illegal or restricted in various areas in the U.S. (more municipalities are making this a consideration) because of the brine discharge of the softener during the regeneration process. Municipal and waste water treatment facilities have an increasing problem with this by-product, which inhibits the ability of delivering the required quality of water to agriculture, the community and your home.



SOFTENING VS. EWS CONDITIONING

PHYSICAL CONDITIONING - INFORMED ALTERNATIVE

The ICN conditioner acts as a catalyst in the water. The bonds that trap foreign particles to water molecules are broken and expose those foreign particles to the open solution. The surfaces of these particles become available as nucleation points for the hardness minerals. The hardness minerals cluster together to form microscopic seed crystals around those nucleation points. This process is called increased calcite nucleation (ICN). All the hardness minerals in the vicinity of these seed crystals eventually come in contact with its surface. The hardness minerals solidify there and no longer have an affinity for hard surfaces with which the water comes in contact.

In order to understand this easier, look at a box of laundry detergent. Years ago, detergents asked you to add more soap in hard water and suds were the visual test. Since 1980, low sudsing formulas were an improvement (suds do not clean, are hard to rinse out, and bad for the appliance) and the detergent does not care whether the water is hard or soft. Detergents add "water conditioners" or ionic and/or anionic surfactants that attract the hardness minerals to their surfaces in a process called increased calcite nucleation (ICN). A billion-dollar business using the same physical process, incorporated in the Environmental Water System, to the advantage of the consumer and the environment.

The minerals in your water are naturally found in 95% of all freshwater and under no circumstances are considered contaminants. These hardness minerals (calcium and magnesium) are part of the natural balance of water. Low hardness can make water aggressive and corrosive. Adding salts and replacing these minerals becomes foolish and make for warranty and drinking quality issues (due to the sodium or potassium chlorides) and septic and environmental issues (because of the brine discharge). The Environmental Water System - Filtration and Conditioning Appliance does not have any of these issues or limitations.

ENVIRONMENTAL WATER SYSTEMS AND ITS APPROACH

The ICN conditioner is a unique product, exclusive to EWS, Inc. and Environmental Water Systems. Incorporated, as part of the riser manifold within the GAC media, the ICN is a cell containing dissimilar metals that have gone through a specific charging process. The three-dimensional field created by the ICN creates the reaction that it is named after. Environmental Water Systems filters all the water to your home or facility and physically conditions the water preventing the formation of lime scale deposits in your pipes and water heater. Furthermore, physically conditioned water is capable of dissolving formerly deposited scale. This water tends to sheet, allowing for faster drying times. Any water that does evaporate on a surface may leave a spot due to total dissolved solids in the water. However, this is easily wiped away, as opposed to untreated hard water spotting, which adheres to surfaces. In addition, aerators and shower heads may develop a ring that should be easy to wipe off, depending on the faucet, water flow and water conditions. A further benefit of our conditioned water is that it allows for better assimilation of anything added to it. You get better lather in your hand soaps and shampoos, and savings on detergent soaps and cleaners. Even the amount of coffee or tea can be reduced according to taste.

Along with this conditioned effect, which is a benefit to you, your home and the products therein, do not underestimate the value of filtered water throughout your home. Do not lose sight of the fact that the reason for water is for consumption, to the benefit of you and your family. Environmental concerns and the pollution and improper use of water supplies effect us all. With aesthetics being important in our culture, it is a distant second to the consumption quality of our water and the polluting of our water supplies.

COMMON SENSE - BE INFORMED AND NOT SOLD

Although nothing is perfect regarding water; you still have to wipe it off the counter, black surfaces will show more, low flow toilets require more work than old ones, small openings will eventually clog, sunlight will bake water on surfaces. We ask to you to use your common sense and be an informed consumer. Both Environmental Water Systems and softeners prevent buildup in your pipes and water heaters. Both allow an easier wipe down of water spots and maintenance of problems associated with hard water. However, Environmental Water Systems conditions and filters all the water to your home, softeners do not. Environmental Water Systems does not use salt or potassium chloride to produce the desired effect and therefore does not require the separate plumbing lines or the maintenance of the softener and other filtration devices at a sink. Environmental Water Systems provide a pleasurable showering experience, where the water feels clean coming on and off; without the slippery feeling the softener provides, yet both systems allow you to wipe down your shower enclosure effectively.

As a manufacturer of a complete line of water treatment product, EWS, Inc. makes Environmental Water Systems and, ironically, the most efficient softeners in the market today. We are just providing you, the consumer, a choice in your treatment options. Be Informed, Not Sold



EWS CONDITIONED WATER BENEFITS

A Common Sense Approach

Ask yourself, if the desired water effects are similar, why deal with the nutritional, consumption, quality, maintenance, aggressive/corrosive and environmental disadvantages of a softener, when an Environmental Water System offers benefits similar to the softener without the disadvantages. Ever see the prices on softeners and their companion reverse osmosis systems? They are either higher or competitive with an EWS unit. However, cheap units are available in local markets. These units are just that, cheap! By the time you use your salt or the costlier potassium chloride, the wasted water, the R.O. pre and post-filters and the membrane replacement, your cheap unit is more costly than an EWS unit without all the benefits.

Just a note. The ICN conditioner is not a magnet. The ICN conditioner is a unique product that creates a virtually permanent reaction. Magnets and other devices work over short distances and over short periods of time, therefore the results are not as beneficial for residential use. Magnets and pulse devices temporarily suspend the minerals and do not create the nucleation effect that is so effective to physically condition the water.

Throughout the U.S., the technique of selling water product at the door is something Environmental Water Systems does not engage in. The appointment setting, the give-a-ways, and the hard sell is left to those that are selling a flawed product. You don't buy a refrigerator this way?! Why trust your water to this approach? Be informed. Compare our benefits. Environmental Water Systems is the only appliance in the water business. Showcased by the National Association of Home Builders and in a survey selected as a "Favorite 50" product by Builder Magazine and ranked 15 of the top 150 products surveyed by Building Products Magazine. Please read the answers to frequently asked questions and consult with your local appliance, plumbing products dealer or kitchen and bath showroom.

Conditioned Water Benefits, An Alternative to Softening Without the Disadvantages

Environmental Water Systems conditions your water for a healthier lifestyle. EWS water conditioning causes a physical change in the minerals found in your water. In each unit the water is filtered through the Granular Activated Carbon then conditioned as it passes through the ICN conditioner. The ICN conditioner breaks apart calcium and magnesium minerals that easily adhere to surfaces (including your skin) into small nuclei with concentric patterns which no longer adhere to surfaces and actively inhibits scale formation.

EWS will filter and condition your water. What does that mean for you and your family? First, your body is between 70 and 80 percent water. Water is the key to every body function especially the circulatory, assimilation, digestive, elimination and temperature control systems. Your body takes in vital water from various sources; orally by drinking, direct skin absorption and inhalation. Chemicals and other substances may be absorbed into the body that are contained in the water. Conditioned and filtered water removes agents such as chlorine. Chlorine plays havoc with our skin and hair because it chemically bonds with the protein in our bodies. It makes hair brittle and dry; it can make sensitive skin dry, flaky and itchy.

Q: Would you purchase a water system that removes your essential minerals and replaces them with salt?

A: Of course not. However, that is exactly what traditional softeners do.

Benefits:

- * Better tasting, quality, chlorine-free water to your entire home
- * Great for drinking, cooking, bathing, showering and all uses
- * Healthier skin, hair and body systems
- * Luxury bath, steam, sauna, and shower
- * Natural water balance
- * No slippery, slimy feeling in the shower
- * Inhibits scale and corrosion in pipes and water heaters
- * Reduces previous sediment build-up in pipes and heaters
- * Easier to wipe up and clean up
- * Use less soaps and conditioners
- * Reduces drying time and heat to dry
- * Environmentally safe, no brine discharge
- * No salts or chemicals to add, No environmental restrictions, No continual maintenance expense
- * No loops or bypasses to avoid the softened water
- * No warranty issues with other products as a result of the salts



FREQUENTLY ASKED QUESTIONS AND ANSWERS

Over the years we have been asked and have answered many questions. The following are a sample of some popular questions to give you some perspective.

Q: How does Environmental Water taste?

A: Even though taste is subjective and very personal. Opinions vary, however, customers refer to our water as tasting like "country" water of yesteryear. They report our water is "smooth", natural tasting, has "vitality", is "sparkling clear" and has no odor. Many of our customers report, "We really enjoy drinking our water," and "We are now drinking more water." Water is necessary to the body, which is composed mainly of water. The body loses water through elimination and perspiration from 3-6 pints of water a day. More water is lost if working or exercising hard. This water should be replaced with quality water. The kidneys process 100 gallons of water a day. Clean water (6-8 glasses a day) is a necessity in flushing out impurities. Water is one of the four main nutrients of the body and the most often overlooked.

Q: How does the feel of Environmental Water compare to salt softened water?

A: EWS conditioned water is not mushy soft nor does it have that slippery, soapy-feel of softened water, that never seems to wash off. EWS water comes on and rinses off completely with a nice clean feeling. Most customers prefer the "squeaky clean" feel of Environmental Water than that of a softener, however this is a personal choice.

Q: How do washing and cleaning results compare to salt-softened water?

A: Surveys of our customers show that washing and cleaning with EWS is comparable to salt-softened water. Customers use less soaps, shampoos, cleaning materials, than they used when their hard water was untreated. Customers report that they no longer use fabric softener, anti-static sheets, or hair conditioners. They also report that their clothes and hair dry faster, thus saving on time and energy costs.

Q: Will the Environmental Water System with ICN help prevent scale in my home?

A: Yes. In fact, our system will even help remove the existing build-up in water pipes and water-using appliances. Removing scale and corrosion will prolong the life of your water heater, your appliances, and plumbing fixtures. It will also reduce your energy costs. Hot water heaters with scale build-up require more energy to heat the water. Keep in mind, softeners use salt, EWS does not; Salt is known to be corrosive.

Q: Where should the Environmental Water System be installed?

A: The EWS should ideally be installed on the main water line of your home to treat all the water in your home. This can be determined by your builder or plumber. If you locate the main water shut off valve to your home, the pipe thereafter will supply all the water to the unit. Be careful of soft water loops which bypass certain pipes that should not be softened. Treat and protect the system like you would a water heater. A garage, basement or utility room install is fine. Take care with outside installations and take the logical steps to protect the systems from the elements.

Q: How much maintenance is required of the Environmental Water System?

A: Every few years, the GAC media and ICN(s) should be replaced as a replacement kit within the tank. Historically, our field surveys show 7-10 years of useful life. EWS, Inc. typically recommends every 7-8 years depending on local water conditions and usage. Proper application, installation, set-up and backwashing effects the useful life. However, no salt, chemicals, filters, or other supplies need to be bought and added or changed on a monthly or annual basis. The automatic system requires no maintenance. A digital timer is set to automatically backwash (clean out) the carbon bed. The backwash water can be used to water a garden area so no water is wasted. Plants flourish on this water. This water can also be put into a drain line with no detrimental effects to septic tanks or sewer lines.

**Q & A****Q: Will my ice cubes be clear?**

A: No. Water is very unique. Clarity of ice is not a quality issue or consideration. Water expands when it freezes and contracts when heated. Water freezes from the outside in. The minerals, being heavier than water, go toward the center and freeze last. The clouded appearance of ice cubes is due to minerals and air. Likewise, when ice melts, the minerals being heavier may drop in the water. Thus, the little flecks you see are actually the heavier minerals. You'll note these will dissolve or blend back into the water as the water temperature increases. Reverse osmosis water will make clearer ice cubes because 90-95% of the minerals are removed. The average home refrigerator ice cube makers inject a lot of air so that even reverse osmosis ice cubes will not be perfectly clear. Reverse osmosis must be plumbed in plastic to ice-makers. Copper tubing, which contains copper and aluminum, cannot be used. RO water is aggressive, and will pull or leach copper and aluminum from the tubing, making the water and ice taste metallic. Please consult your refrigerator manufacturer regarding potential warranty issues regarding softeners and reverse osmosis units. Some ice skating rinks are now using de-ionized water (water with little or no minerals). The drawback is the solvency, (the aggressiveness of water without minerals) reacting to the surface of the rink itself and the equipment. Good Housekeeping Institute's Appliance Lab states "for crystal-clear cubes, you need a professional ice-making machine". Commercial ice-makers work on a quick freeze from one side to another so that the minerals are sloughed off, thus producing clear ice cubes mechanically.

Q: How will I know when I need to change out the carbon?

A: The standard system, the EWS-1054, has 11/2 cubic feet of carbon (approx. 41 lbs.). We use a high grade GAC. Based on general estimates, this amount of GAC will be effective in removing chlorine from normally treated municipal water for approximately one million gallons. Because of variations in water treatment and usage, there is no guarantee on the life of the carbon. The average family uses about 100,000 gallons of water a year in their home (not including what is used on lawn areas for watering). One hundred gallons of water per day per person is the usual estimate on water usage. When the carbon reaches its saturation point (all the internal pore surfaces are filled) the water will change in taste back to your regular tap water. A pool test kit that tests for the presence of chlorine is the easiest way to test if the GAC media is still effective.

Q: How is the carbon changed out?

A: The system is put on bypass by turning off the water to the system. Relieve the pressure in the tank by cycling the valve into a backwash. Remaining water will expel, then air as pressure is relieved. Disconnect the backwash/drain line and unplug the system. Disconnect the valve head from the bypass, allowing the tank to pull away from the pipes. Unscrew the valve head and lift off. The carbon and water in the tank can either be dumped out, hosed out with water, or a wet/dry vacuum can be used to suck out the water and wet carbon. Once the water, carbon and ICN riser manifold are removed, a complete kit that contains the new ICN riser manifold and the correct amount of GAC media is supplied making this an easy process. The carbon will fill 2/3 of the tank, which allows 1/3 of freeboard area, which is necessary for backwashing purposes. Once media is replaced, pre-fill the tank with water, then screw on the valve head and reconnect the tank to the bypass. Reconnect the backwash line. Follow the same start-up procedures when the unit was first installed.

All this information is in our complete service guides and also available on the web. Replacement kits can be easily obtained by contacting your local distributor, plumber, website, or our local representation.

**Q & A**

Q: What are the real differences between salt softened water and the Environmental Water System providing filtration and conditioning?

SALT-SOFTENED WATER

PRINCIPLE

Salt softened water is based on ionic exchange. For each calcium and magnesium ion (the hardness minerals) two sodium ions go into the water. A traditional softener using salt does not filter chlorine, volatile organic compounds, nor is it considered a filtration system. A salt softener usually has a reverse osmosis system at the kitchen sink to remove the sodium added to the water that the softener put in.

FEEL

Salt-softened water feels mushy and has a slippery or slimy feel when bathing with soap. Those not liking the softened feeling feel as if they can't get the soap off. The skin feels like it has a coating on it. Consumers are told that salt softeners bring out the natural oils of the body by those trying to sell them a salt system. This is not true. If you like the slippery feeling, restrict your softener usage to the inlet side of the water heater, in order to soften to the hot side only.

AESTHETICS

Salt softeners, by removing the hardness minerals of calcium and magnesium, can prevent the scale build-up in pipes and water heaters. Because of the sodium content, softened water unites with soap limiting bathtub rings, allows better results with clothes washers and dishwashers, and leaves shower doors virtually free of the usual soap scum build-up. Most laundry and dishwashing detergents contain a lot of sodium. Sodium causes more suds, however suds do not clean. Even though the minerals are gone, the total dissolved solids in the water has not changed and therefore when water is left, it will leave a residue on surfaces or around faucets which simply wipe up. Salt softened water can also cause spotting depending on how much sodium is in the water.

SALT IS CORROSIVE

Those in the Navy are familiar with the term "Marine Whites." Sailors used to put their white clothes in ocean water to whiten them. Caution had to be used because if the clothes remained too long in the heavily salt-laden water, they would deteriorate. Salt is corrosive. Softeners use the same salt that is spread on icy roads, which destroys the underside of cars. Those living near oceans know well the corrosivity of salt to cars, houses, etc. Many people with galvanized pipes found that softened water did prevent scale build-up, but the trade-off was the salt also corroded their pipes.

It's interesting to note how many water heaters people with softened water go through in some areas. The salt (sodium) corrodes the heating coils of the hot water heaters. Always check with a manufacturer's warranty as related to water. Softened water should not go to a pool or spa. Hard water and naturally soft water have their maintenance issues, however softened water offers potential problems that may imply or outright void the warranty on certain products.

THE ENVIRONMENTAL WATER SYSTEM (EWS)

PRINCIPLE

The EWS combines both filtration and conditioning in one system. The filtration is accomplished with a high grade of Granular Activated Carbon (GAC). Used extensively in both water and air filtration, GAC works on the principle of adsorption, in which substances in water are attracted to and adhere to the surface of the carbon. GAC is carbon that has been activated to produce an extensive intricate inner pore structure with a large surface area.



THE ENVIRONMENTAL WATER SYSTEM (EWS) - Continued

GAC is most widely used for the removal of chlorine, chloramines (chlorine and ammonia), bad taste and odors. It is also used to remove volatile organic compounds, phenols, herbicides, pesticides, and surfactants. Most minerals, having the same polarity as carbon, are not removed when filtering through carbon. Carbon is the last stage in both reverse osmosis and distillation systems for removal of chlorine and volatile organic compounds.

The ICN Conditioner causes a physical change of the minerals. There is a breaking apart into tiny nuclei. Operating on principles of polarity, the calcium and magnesium are attracted to tiny nuclei rather than attaching to pipes. The minerals are put into a suspended state, making them less adhering. Technically, this is called "increased calcite nucleation".

FEEL

Environmental Water has more of the feel of naturally soft water (water with lower mineral content). It does not feel slippery, slimy, or mushy soft, like salt softened water. No water in its natural state feels like salt softened water. Soaps produce more lather with EWS filtered water versus untreated water. However, these soaps will rinse off quickly, unlike salt softened water. Those who don't like salt softened water say they feel they can't really get the soap off. Less soaps, shampoos, coffee grounds, tea, etc., are needed with an EWS system. Most people will use less soap than they would normally use with untreated water.

AESTHETICS

EWS conditioned water will tend to sheet. If water is left to dry on any surface it will leave something behind. These spots will simply wipe off versus untreated water where more work and special products may have to be used. Those that have had a salt softener must be told that there will be less suds with EWS water. The sodium content of salt softened water causes more suds. This is particularly true with some of the biodegradable laundry detergents. You should not use more soap to get more suds. Clothes will get clean without the excess soap and suds and rinse out and dry easier. The same with your dishwasher, use the appliance properly and with less powdered detergent.

When showering, EWS water rinses off quickly. Those accustomed to the slippery feel of salt softened water sometimes try using more soap or a gel to get that same feeling, resulting in more soap usage and soap scum build-up. Salt softened water unites with the soap, leaving little soap scum. This is not true with EWS. Using less soap and rinsing well will help prevent this. EWS makes the water easier to clean up just like a softener (our approach is different) however this does not preclude you from your routine maintenance. A dishwasher still needs to be used properly, toilets need to be cleaned, and surfaces need to be wiped off. The use of a surface sealant when the shower is new or has just been cleaned will also make clean-up easier. If there is a lot of soap scum because of frequent usage without clean-up, effective products that are non-abrasive are all that are recommended. An environmental alternative is hot water and plain white vinegar. Check with the manufacturer of your appliances and other household products, including your surfaces, for the best way to seal, clean and/or maintain. Some cleaning practices may not be effective, or have an adverse effect to the life of the product.

An EWS application allows you to clean up easier than your untreated water, saves on soaps, keeps your plumbing clear and filters to the entire home. Our service guides contain helpful hints regarding the care of a wide variety of products. Since we distribute through appliance, plumbing and kitchen and bath showrooms our extensive knowledge of these appliances, products and surfaces can be of benefit to you.

EWS water will prevent scale and corrosion in pipes and will de-scale as the scale is attracted to the nuclei. Older water heaters should be drained to remove scale and sediment after an initial installation. Water heaters will work more efficiently, and a savings on fuel will result. After de-scaling water heaters, they should be drained at least once a year to remove powdery calcium and magnesium caused by the nucleation effect. Water heater manufacturers recommend this procedure as preventive maintenance.



Q & A

Q: How does EWS compare to reverse osmosis water?

A: Reverse Osmosis works on the opposite (reverse) of the osmosis process. This means that the water goes first through a pre-sediment filter, then a carbon filter (for chlorine removal and to protect the membrane from deterioration), and through a membrane where only the lighter water can squeeze through. The heavier elements (mostly minerals) will be sent down the drain, the filtered water into a storage tank.

In the reverse osmosis process, about 1 gallon an hour can be made by our standard systems. For every gallon of water put into the storage tank, about 4 or more gallons can go down the drain. The standard storage tank holds 3 gallons of water. The water is continually running until the tank is full at which time the water shuts off. Reverse osmosis systems are almost always used when one has a salt softener to take out the sodium the softener put in. They also remove 90-95% of all the minerals, producing a flatter tasting water. Many bottled waters add minerals to the water to give it taste or flavor. Mineral or spring waters, bottled at the source, have higher mineral content and are naturally very hard.

Reverse osmosis water is aggressive or highly solvent with the removal of the minerals. Water seeks out minerals to balance itself; thus RO water must be plumbed in plastic or PVC. Copper tubing consists of copper and aluminum, the RO water will pull (leach) the copper and aluminum into the water, giving it a metallic taste. This leaching effect is the same with cooking and drinking. The common complaints against reverse osmosis systems are:

- a) How much water is wasted
- b) Flat-tasting
- c) Expensive up-keep. Pre-sediment filters and carbon filters need to be changed once or twice a year and membranes every 2 years, or as the manufacturer suggests.

Reverse osmosis units are necessary when dealing with extreme problems such as nitrates in the water. If a customer has an RO system, keep it, then decide which water they prefer to drink. As with everything, different people like different things. That is why on the supermarket shelves there are dozens of different types of bottled drinking waters. Those accustomed to reverse osmosis water may not like the taste of minerals, while others love EWS water because it tastes more like spring or bottled water.

EWS, Inc. does manufacture reverse osmosis systems for correct applications, which waste less water and produce more water per day. Visit our website at www.EWSWATER.com for this and other units that may be correct for you, your concerns and/or your water conditions. Any and all of our systems can be used in combination with each other to get the desired effect.

Q: Does bacteria grow in a carbon system?

A: EWS and all water filtration and treatment systems are designed for potable water (water without coliform bacteria). Municipally treated water generally uses some form of treatment, usually chlorine or chloramines, to destroy coliform bacteria. Municipally treated water is continually tested to make sure that there is no coliform bacteria present. For well water applications it is really important to have an independent laboratory take samples and test that the well is bacteria free. This should be done routinely to ensure "safe" drinking water.

Coliform bacteria is bacteria from human or animal fecal waste. Its presence is an indicator of potential diseases or illnesses that could result from consuming the water. By law, there can be NO coliform in municipally treated water. There are many types of bacteria, both good and bad. Bacteria is needed in the human colon for processing wastes. Many people buy milk and yogurt, as well as other dairy products, with acidophilus to provide this good bacteria. Bacteria itself is present everywhere - in the air, on the surface and in what we eat and drink. A heterotrophic plate count indicates the number of colonies of bacteria in general. Milk, for instance, is allowed to contain 10,000 colonies of bacteria (excluding coliform. of course.)



Bacteria can grow in carbon. One of the reasons for backwashing is to prevent this growth. EPA studies show that backwashing serves to minimize any growth. The EPA has also conducted studies showing no ill effects from drinking water with a higher heterotrophic plate count. Currently there is no maximum standard for heterotrophic bacteria. Those individuals who dwell on this issue fail to realize that all drinking water systems use carbon. Carbon block filters can develop bacteria. The carbon filters at the end of reverse osmosis membranes can develop bacteria. And reverse osmosis membranes can also become fouled with bacterial growth. The carbon filters used in drinking water systems generally do not allow for backwashing, which serves to clean the carbon. That is one of the reasons why smaller carbon filters should be changed routinely based on the manufacturer's recommendations. Carbon drinking water systems and reverse osmosis systems are designed to be put on only potable water - water free of coliform bacteria.

Q: What is the purpose of backwashing?

A: In backwashing, the water goes down the riser tube, lifts and turbulates the carbon with the water coming out of the backwash drain line. The tank is filled 2/3 full of carbon, which allows the remaining 1/3 as a freeboard area - room for the carbon to swirl around without being forced out the backwash line. A top screen on the valve head protects the valve head from any carbon lodging in it. Backwashing serves to force out dirt and sediment, rearrange the tiny granules of carbon, prevent any channeling by re-fluffing the carbon bed, and discouraging any bacterial growth.

Frequency days for backwashing will vary, based on the hardness of the water. Las Vegas and Arizona, for example, use a 3 day backwash cycle. No system should go beyond 12 days without a backwash. Water usage, dirt in the water, and the type of water (hardness, alkalinity, high TDS), are what govern the day setting. Manual backwashing can always be done which allows for greater agitation of the bed. This is necessary, for example, if a great deal of dirt gets into the tank from repair or construction on water lines in the area. When you vacation or leave for an extended period, set to backwash infrequently and re-set when you return. Never shut down the system completely for any length of time.

Q: Are there other types or alternatives besides the Environmental Water System with ICN conditioner?

MAGNETS

Magnets operate for short distances - usually less than 125 feet. Thus, magnets must be installed at several places for long pipe runs. Magnetically treated water also reverts within 36-72 hours. Therefore, magnets are usually placed on the outlet side of a water heater in which water can stand for long periods or water has to be constantly recirculating past the device to work. Magnets also require grounding, as do some of the catalytic bars. Magnetic polarity can be disrupted by high power lines and by the ground itself. There are too many magnets misapplied and misrepresented as cheap alternatives to harsh softening.

ULTRASOUND

This is a device that uses ultrasound vibrations to create a nucleation effect. The system plugs into an electrical outlet and then uses a wrap of wire around the water pipe to conduct the ultrasound vibration into the water. In the 50's, the United States Government conducted tests using ultrasound. The vibrations created by this process literally caused dirt to fall off of laundry. Consumers report the pipe is clean where the pipe is wrapped but no further. The technology has not been fully developed in the water industry.

Unlike the other alternatives, EWS has been very low-key, is not sold door to door and has been available next to the finest appliances, faucets and fixtures throughout the building industry and kitchen and bath showrooms. We have combined the very accepted filtration aspects of granular activated carbon with the ICN Conditioner.

**Q & A****Q: Chlorine in salt-softened water? Why don't I get a reading on chlorine if a person has a salt-softener and the outside water shows chlorine?**

A: The softener tank with the resin holds 6-10 gallons of water. If the water has been sitting in that tank for a few hours with little or no use, the resin will have reacted with the chlorine, causing it to break down. Chlorine will also dissipate when it sits in the water heater for a few hours. If a person takes a shower or does a load of wash, the water in the tank is used up and the new water going through will not have the prolonged contact time and the chlorine will come through. Be aware - these man-made resins in a softener break down with usage in chlorinated municipal water. The resin materials that break down and go into your water are a point of interest. Manufacturers compete on the facts that their resin may not add certain known contaminants as much as a competitor. EWS - NO SOFTENER, NO SALTS, NO RESINS, NO BRINE, NO PROBLEMS!

Q: What is Potassium Chloride or the "no salt" alternative?

A: It's not bananas or a healthy potassium (K). It is potassium chloride (KCl), a substitute for salt (sodium chloride) to "soften" the water. It is also based on ionic exchange. The drawbacks to potassium chloride are:

- a) Anyone with diabetes, heart disease or other conditions should be advised that the use of this product with the increased potassium chloride intake might be a concern to their health and may negate the medications used to treat these conditions. Let's face it! It's still a salt, but the semantics make for a good sales pitch.
- b) The maintenance of adding potassium chloride to the brine tank is the same as salt, however the potassium chloride is more expensive.
- c) During regeneration, excessive amounts of chlorides (as well as TDS) are being put back into our municipal water supply. Those with septic tanks should consider that the brine discharge inhibits the bacteria necessary in the septic tank from doing their job.
- d) Valuable calcium and magnesium are still being removed from the water.

Q: How do I determine what system is right for me?

A: The size of your home, the number of bathrooms, the size of the family, the size of the pipe supplying the water to the home, the hardness of the water and your personal habits and considerations - all determine the best system for you and your home. Certain considerations will immediately indicate the proper system. The standard home unit (EWS-1054) is proper for most applications with these exceptions: The service line is 1 1/4" or greater, the hardness of the water exceeds 15 grains or 257 mg/l, five or more people reside in the home, the home exceeds 4,000 square feet, and/or there will be a considerable usage of water, two or more water heaters, etc. The upgraded or larger residential unit (EWS-1354 series) is applicable with all the above exceptions. The larger units have valve options to accommodate larger main services and better water flow rates. The increase in tank size allows for an extra cubic foot of GAC for greater filtration capabilities, and an additional ICN conditioner for better conditioning effects and aesthetics. Discuss this with your local distributor. You may have to ask your builder or plumber the correct question or two, but the result is a correct unit for your current and/or future needs.

It is our hope...

...that we have provided you with as much information as possible on filtration and conditioning. Any additional questions you may have, that have not been answered in these sections, may be answered in our installation, customer service and troubleshooting guide. This guide is available, and is enclosed with every unit or available on the web. Do not let your installer discard this information. Installation is very simple, however an incorrect install or a total disregard of start up procedures is usually the only problem (easily corrected) we have had with any systems since our inception in 1979.



Acknowledgements

BUILDING PRODUCTS 15



15. Environmental Water Systems. This whole-house filtration system, which hooks to the main shutoff valve, does not require a bypass. It filters water through activated carbon granules to mitigate chlorine and odors. The no-salt conditioner suspends hardness of minerals to reduce scale buildup and help retain nutrients. 702-256-8182. Circle 107

READERS RESPOND

BUILDING PRODUCTS presents the TOP 150 products readers requested information about during the past year.



Environmental Water Systems is the ultimate appliance in water filtration and physical conditioning. Installed at the main service line, Environmental Water Systems provides filtered water to the home while helping to solve problems associated with hard water. Unlike traditional water softeners, Environmental Water Systems gives customers the benefits of filtered water to the entire home. Conditioned water prevents buildup in pipes and water heaters, cuts down on soap use and cleans up easier without removing beneficial minerals.

The Community Water Line, from sink to the whole home, the products, prices and programs to satisfy distributor's, builder's, and consumer's needs.

October 1998



Reprinted from the May/June 1998 issue of BUILDING PRODUCTS Magazine © Hanley-Wood, Inc.

BUILDING PRODUCTS Magazine BUILDING PRODUCTS Magazine's Top 150 Product Picks!

Ranked No. 15: Environmental Water Systems:

This whole house filtration system, which hooks to the main shutoff valve, does not require a bypass. It filters water through activated carbon granules to mitigate chlorine and odors. The no-salt conditioner suspends hardness of minerals to reduce scale buildup and help retain nutrients.

Environmental Water Systems is the ultimate appliance in water filtration and physical conditioning. Installed at the main service line, Environmental Water Systems provides filtered water to the home while helping to solve problems associated with hard water. Unlike traditional water softeners, Environmental Water Systems gives customers the benefits of filtered water to the entire home. Conditioned water prevents build up in pipes and water heaters, cuts down on soap use and cleans up easier without removing beneficial minerals. From sink to the whole home; the products, prices and programs to satisfy distributor's, builder's, and consumer's needs.

(Reprinted from the May/June 1998 issue of Building Products Magazine © Hanley-Wood Inc.)

BUILDER Magazine
December 1996

Environmental Water
Systems

"Favorite 50"

"Whole-house, no-salt conditioning and filtration system was installed. Water is filtered through activated carbon granules to eliminate chlorine and odor. Integral conditioner places minerals that cause hardness into suspension so they adhere less, manufacturer claims. System fits in single tank; installation is similar to that of typical water softener. Automatic timer takes care of backwash; because there is no salt, backwash can be directed to lawn and garden or drain lines, company says."

114

BUILDING

FAVORITE 50



WATER PURIFICATION SYSTEMS

Environmental Water Systems: Whole-house filtration system hooks to main shutoff valve and requires no bypass. Filters water through activated carbon granules to mitigate chlorine and odors. No-salt conditioner suspends hardness of minerals to reduce scale buildup and help keep nutrients. 702-256-8182. Circle no. 117



BUILDER Magazine -
January 1994

Environmental Water
Systems

"The New American Home"

Featured water filtration product in the showcase home of the National Association of Home Builders Annual Show. "Environmental Water Systems: Whole house filtration system hooks to main shutoff valve and requires no bypass. Filters water through activated carbon granules to mitigate chlorine and odors. No-salt conditioner suspends hardness of minerals to reduce scale buildup and help keep nutrients."



FDA, EPA and NSF Compliances

1) Please be advised all the materials and components utilized in producing these POE and POU filtration, drinking water, and reverse osmosis systems comply with, but not limited to, one or more of the following regulating standards:

NSF STANDARD 14	FDA 21 CFR 177.1520	FDA 21CFR 177.1640	FDA 21 CFR 177.1350
FDA 21 CFR 175.105	CAS # 7440-44-0	ANSI 304	CDA C360000
NSF STANDARDS 60 AND 61	NSF STANDARD 58	ANSI 302	ANSI 316
FDA 21 CFR 177.2600	FDA 21 CFR 175.300	FDA 21 CFR 177.2550	NSF STANDARD 52
NSF STANDARD 42	NSF STANDARD 18	FDA 21 CFR 177.2550	FDA 21 CFR 177.1655
FDA 21 CFR 177.1630	FDA 21 CFR 177.2800	FDA 21 CFR 175.300	FDA 21 CFR 177.2260
FDA 21 CFR 181.32	FDA 21 CFR 177.2660	FDA 21 CFR 177.1950	FDA 21 CFR 177.2910
FDA 21 CFR 177.2250	FDA 21 CFR 177.1680	NSF STANDARD 53	NSF STANDARD 55

Most of these standards relate to the Code of Federal Regulations of the United States of America, Title 21, Charter 1, Subchapter B set forth by the U.S. Food and Drug Administration. The NSF (National Sanitation Foundation) standards correlate to materials and potable water.

2) Without exception every component included in any and/or all of our systems are compliant for food and beverage contact and/or meet or comply with the most current appropriate and applicable standards without exception.

3) Performance Guidelines:

Follow EWS, Inc. detailed installation, start-up and maintenance instructions and follow all local plumbing codes. The feed water must comply with the following conditions for the system capabilities, compliances and warranties to remain valid.

■ Water Temperature Range: 40-80°F; Water Pressure: 40-75PSI; All systems must be connected to main or cold water supplies (hot water not to flow through systems). Units always contain water-Do not allow unit to freeze.Do not use where water is micro-biologically unsafe or with water of unknown quality without adequate disinfection before or after the unit.

■ Reverse Osmosis Systems Only - Never allow reject water to be stopped, without the reject water flow or improper drain connection impurities may build up on membrane. POE Units - Do not prevent backwash or brine lines to be stopped or restricted.

4) Factory Preparation:

All systems are factory prepared and checked to assure proper function and if applicable, quality tests of product water produced to assure that minimum standards of rejection have been met, tests of specific components to assure correct function and flow rate measurements to assure efficiency specifications are met.

5) Know your water:

■ If on a municipal system, large or small, it is your right as a consumer to have access to the most recent test results and to expect adherence to federal guidelines, as well as, any state or local requirements. Any problems should be reported to the appropriate agencies. Please acquire those municipal test results to become an informed consumer.

■ If on your own individual well, have your water completely and independently tested. Local code may require a simple test for coliform bacteria to approve a well, however you may be unaware of potential problems for you and/or your home. Review our section on well water testing and applications in our complete catalog or visit our website.

The contaminants or other substances removed or reduced by these and other water filtration devices are not necessarily in your water. Performance may vary based on local water conditions. To confirm the presence of any contaminants, have your water supply analyzed by an independent and approved facility. Not intended for use where water is microbiologically unsafe or with water of unknown quality without adequate disinfection before or after unit(s). To ensure proper operation, follow installation procedures. Filter maintenance schedule will vary and must be replaced, as necessary, as determined by usage and local water conditions. Contaminants and/or constituents, primary and secondary and aesthetic aspects of water, as known and acknowledged by the EPA and The Clean Water Act, will be the only basis with which test results and information will be accepted and validated.

Proper application (systems being used for the correct reason), setup, installation, startup and maintenance are crucial to insure proper water quality and warranties. Taste and aesthetics are personal and subjective.

See additional information for all filtration removal capabilities, rejection rates and system tolerances.



Media Replacement

GAC Media and ICN(s) Replacement and Kit EWS Series - Filtration and Physical Conditioning

Filter Code No: POE-10 Model No.: ICN/GAC1054

1 1/2 cu. ft. GAC media and ICN Replacement Kit for EWS 1054 tank

Filter Code No: POE-11 Model No.: ICN/GAC1354

2 1/2 cu. ft. GAC media and ICN(2) Replacements Kit for EWS 1354 tank

1) Granular Activated Carbon - Primary Media

Color: Black Form: Granular
Mesh Size: 12 x 40 Density: 33lb.s / cu. ft.
Water Soluble Ash: less than 0.5%
Iodine No.: 1200 Abrasion No.: 75 min.
Meets American Water Works Assn. Standard -B604-74

2) Stage 2: (Filter Ag)

ADVANTAGES:

- * Acts as a Pre-Sediment (20 micron) media
- * Less pressure loss, increased filter capacity
- * Light weight reduces shipping costs and lower backwash rates.

3) Stage 3: (Under Bed)

Under Bed Keeps riser in place and allows better water distribution through filtration and backwash.

PHYSICAL PROPERTIES:

Color: - Light grey to near white
Density: 24 - 26 lbs. / cu. ft.
Effective Size - 0.57 mm
Uniformity Coefficient - 1.66

CONDITIONS FOR OPERATION:

Maximum Temperature - 140F - 60C
Bed depth - 24 - 36 in
Backwash Rate - 8 -10 gpm / sq. ft.
Backwash Expansion Rate: 35 - 50% of bed depth
Service Flow Rate - 5 gpm / sq. ft.

* Media/ICN(s) replacement based on local water conditions and usage, proper installation and routine maintenance.

Typically, we have demonstrated years between replacements. See GAC reference chart

Stage 4: ICN Conditioning Unit

(EWS-1054 contains one; EWS-1354 Series contains two for greater conditioning capabilities)

The ICN's Field triggers a reaction (increased calcite nucleation) that changes the structure of the minerals as they relate to water molecules. Minerals become suspended and form concentric patterns into free floating disks which make the hardness minerals attach to each other and no longer adhere to hard surfaces. The ICN unit is a series of dissimilar metals which creates the field that triggers this reaction (This is not a magnet). This conditioning (not softening) process is used widely around the world.

The ICN is part of the riser manifold which distributes water through the tank. Once filtered, water is forced through the riser and the ICN(s) to increase the catalytic effect of the conditioners.



The “Salesperson Cometh!” and other amusing, insightful, and useful hints

You’ve bought a major appliance and a competitor’s brand has just rung your doorbell. He asks you what you bought and proceeds to tell you horror stories about that product. Low and behold, he has a test – he explains that what you bought is garbage and he can sell you what you need.

Sounds ridiculous, but it happens every day in the “water business.” The salesman at your door has something to sell and he earns a nice commission. He will test for minerals in your water, the same minerals found in bottled water (Coca-Cola adds minerals to provide flavor and taste to their Dasani bottled water) and especially those bottled at the source (Evian, Perrier, and Pellegrino, to name a few). The salesman explains that they’re contaminants and that if you don’t remove them, your investment in your home will be doomed. This will be only the first of many lies or pieces of misinformation you will hear, but maybe you’ll receive a nice clock or steak knives for that test and your time. Maybe you’ll even receive a free year’s worth of soap to go with your overpriced softener. Don’t forget the reverse osmosis system for the sink, or maybe bottled drinking water delivery - wait a minute, didn’t you just buy a water treatment system? Why do you need a filter at the sink or bottled drinking water? Don’t forget about salt delivery, a system maintenance agreement, or that wonderful lease (add up your costs).

The reality is, our product was either on display or made available through a Kitchen & Bath Showroom, a building/plumbing/appliance supply company, or your builder and/or plumbing subcontractor. No one came to your door with a bogus test which is slanted to their “pitch.” No one sold you. You were provided information on which to base your decision. You purchased your Environmental Water System in the same manner you selected your other fine appliances. With the proper installation and usage, you will enjoy your system for many years to come.

Just a note: when the salesman says or shows you that your EWS is not softening because your water is not soft (“this thing is not working!”), just remember that this salesman tested for minerals (calcium and magnesium). He wants to sell you a softener that removes the minerals and replaces them with salt. **Consider this:** before a softener, you have total dissolved solids of which minerals are a component. After the softener, the minerals are gone, but the total dissolved solids either remained the same or in some cases, increased. What took the place of the minerals? Salt!

Look in this addendum. **Point:** hardness minerals are not contaminants. They are a non-health related, aesthetic issue.

Great Point: you should not drink softened water (hey, if we shouldn’t drink the water, why would we bathe or shower in this stuff?). That is why softeners are bypassed or looped away from the kitchen sink and icemaker. They avoid hose bibs (you’ll kill the plants with softened water) and the pool (you’ll void your pool’s equipment warranty). You’ll also need a reverse osmosis system to remove the salt from the water the softener just put in, just so you have something to drink. **Point:** softeners have a brine discharge that makes it difficult for municipalities to treat the water properly for the same reasons this discharge is not good for septic systems. For this reason and others, softeners have been banned and restricted in many areas throughout the United States. Many other local and state agencies have restrictions pending on softeners. The EWS backwashes water only, there is no discharge. Now you know why salt softeners are sold door-to-door – it’s a hard-sell and a deceiving pitch. The information does not hold up to the proper scrutiny. However, the salesman probably had an answer for everything. **Other issues:** no electricity units incorporate additional valving, which requires more servicing. The electricity used by the EWS valves is about the same a doorbell.

Remember, the salesman may have a “no-salt-potassium” pitch. It’s potassium chloride! It’s another salt! It’s not crushed bananas. Same softener issues, slightly different chemical.

These examples are part of the word games and semantics these companies play. We do not play games. We provide the information to allow you to make an informed decision.

Previous Softener Owners:

You have selected an alternative to a product you either loved or hated, or for most people, never even considered due to the salt and the salesmen. The salt is a hassle, as is the constant cost for upkeep, and the other issues were interesting. For instance, good drinking water was limited to a sink or refrigerator. The water’s slippery feeling can be disagreeable and the water heater rotted out from the bottom due to corrosive salts. EWS provides good drinking water throughout your entire home – it’s not soft, it’s conditioned. That’s correct – if you wanted that slippery, “I can’t get the soap off” feeling, EWS does not provide that (unless you choose to purchase one of our softeners). The slimy feeling was the salt reacting with the soap, not your natural body oils the salesman pitched to you.

If you notice more spots with your EWS unit than with your softener, the salt created that effect corrosively. However, you still had to wipe off things with your old softener. Just simply wipe off our spots – it’s easy and non-corrosive. If your skin feels dry, it’s a transition some softening consumers go through because the skin has become used to the salt. It may last up to 2 weeks, and then you will notice a nice and welcome change. Since we do not use salt and we filter out chlorine, these substances are no longer present to dry out your skin and hair. Long-term usage of our system will be highly beneficial to you. You will use less soap. Your softener created a lot of suds because of the reaction to the salt. However, suds do not clean, the soap does. Please feel free to try other, gentler products on yourself that react better with the natural minerals in your water, and not the salt of sodium or potassium chloride.